



## Gigatherm Gourmet System

# GGM Cam

### With camera

Optimum regeneration quality and food safety thanks to integrated camera



**Powerful microwave cooking and regenerating appliance for professional operation in hospitals, vending systems, petrol stations and shops.**

With the GGM Cam, a gentle, fast and high-quality heating is guaranteed at all times.



### Anti-Cold-Spots-technology

Optimised microwave insertion (1000 Watt) avoids «cold spots»



### 3-phase programming

6 program keys, which can be assigned with up to 3 program steps each



### Quick control

Rotary and push button for quick selection and confirmation



### Audible & visual signal

An optical as well as an acoustic signal at the end of the process



### Continuous operation

Suitable for continuous operation thanks to its solid construction



## Gigatherm Gourmet System

# The symphony of your kitchen

### Professional technology for the gastronomy

Whether combined as a system or as a stand-alone appliance: The Gigatherm Gourmet system can be tailored precisely to the needs of the individual kitchen disciplines. Thanks to its compact design and stackability, it is also suitable for narrow kitchens.



#### **GGH**

Hot air oven  
with adjustable fan



#### **GGM**

Microwave oven with  
Anti-Cold-Spots technology



#### **GGR**

Smoker with vacuum  
technology



Int. Patents reg.

**Technical data**

# GGM Cam



## Microwave oven

with Anti-Cold-Spots-technology

The camera reads in the regeneration programme via the QR label and the microwave can be started.

### General

Appliance type	Microwave cooking oven
Microwave power (W)	1000
Cooking chamber volume (L)	21
Power supply	230 V, 10 A, 50 Hz
Dimensions (H x W x D mm)	312 x 490 x 625
Weight (kg)	34.8

### Finishings

Housing	stainless steel
Display	LCD
Door	glass/black
Door handle	stainless steel, massive
Door latch	magnetic
Door hinge	left

### Features

Cavity size (H x W x D mm)	188 x 328 x 346 (Ø 32 suitable)
Microwave power levels	adjustable in 50-watt steps
6 programme memories	with 3 programme phases each
Cooking timer	max. 30 minutes
Operation	electronic
Continuous operation	suitable
Camera	with QR code reader

### Anti-Cold-Spots-technology

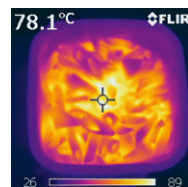

GGM 1000

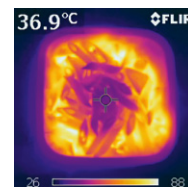

Gastro microwave

Alternatively possible with external reader

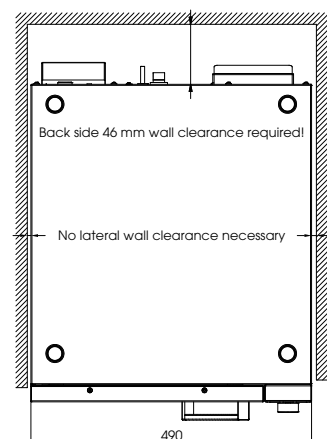
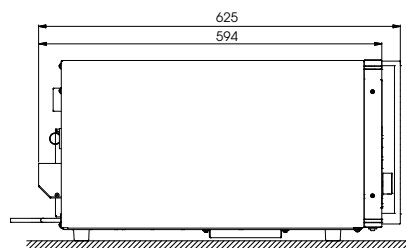
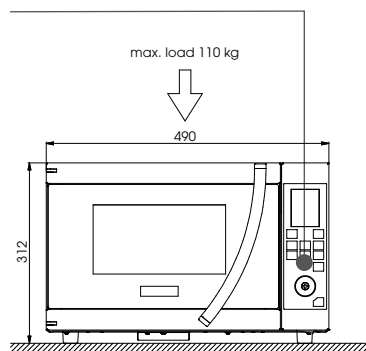

## Gigatherm takes over

entire processes

From food development and preparation to microwave technology for numerous applications and the production of prototypes or entire systems. We are an amalgamation of different competences that complement each other perfectly and have one thing in common: **the development of your solution.** This flexibility makes both our know-how and our range of services extremely comprehensive. For you as a customer, this means innovations that guarantee both time and cost profitability. And always to your taste. Whether in the food sector or in the highly technical engineering sector, and this since 1975.

**Taste, profitability, market needs. Where complex skills are in demand, it takes a company that responds with creative developments. Our favourite language.**